



173

United States Department of the Interior
National Park Service

NATIONAL REGISTER OF HISTORIC PLACES
REGISTRATION FORM

1. NAME OF PROPERTY

HISTORIC NAME: Washington Avenue Bridge
OTHER NAME/SITE NUMBER: N/A

2. LOCATION

STREET & NUMBER: Washington Ave. and Elm Ave. across Brazos River NOT FOR PUBLICATION: N/A
CITY OR TOWN: Waco VICINITY: N/A
STATE: Texas CODE: TX COUNTY: McLennan CODE: 309 ZIP CODE: N/A

3. STATE/FEDERAL AGENCY CERTIFICATION

As the designated authority under the National Historic Preservation Act, as amended, I hereby certify that this x nomination request for determination of eligibility meets the documentation standards for registering properties in the National Register of Historic Places and meets the procedural and professional requirements set forth in 36 CFR Part 60. In my opinion, the property x meets does not meet the National Register criteria. I recommend that this property be considered significant nationally statewide x locally. (See continuation sheet for additional comments.)

Laurie J. Funnell

Signature of certifying official

1-12-98

Date

State Historic Preservation Officer, Texas Historical Commission

State or Federal agency and bureau

In my opinion, the property meets does not meet the National Register criteria. (See continuation sheet for additional comments.)

Signature of commenting or other official

Date

State or Federal agency and bureau

4. NATIONAL PARK SERVICE CERTIFICATION

I hereby certify that this property is:

- entered in the National Register See continuation sheet.
- determined eligible for the National Register See continuation sheet.
- determined not eligible for the National Register
- removed from the National Register
- other (explain):

Edson H. Beall
Signature of the Keeper

Date of Action

2/20/98

5. CLASSIFICATION

OWNERSHIP OF PROPERTY: Public-local

CATEGORY OF PROPERTY: Structure

NUMBER OF RESOURCES WITHIN PROPERTY:	CONTRIBUTING	NONCONTRIBUTING
	0	0 BUILDINGS
	0	0 SITES
	1	0 STRUCTURES
	0	0 OBJECTS
	1	0 TOTAL

NUMBER OF CONTRIBUTING RESOURCES PREVIOUSLY LISTED IN THE NATIONAL REGISTER: 0

NAME OF RELATED MULTIPLE PROPERTY LISTING: N/A

6. FUNCTION OR USE

HISTORIC FUNCTIONS: TRANSPORTATION/road-related = Bridge

CURRENT FUNCTIONS: TRANSPORTATION/road-related = Bridge

7. DESCRIPTION

ARCHITECTURAL CLASSIFICATION: Other: Pennsylvania through-truss

MATERIALS: FOUNDATION CONCRETE

WALLS N/A

ROOF N/A

OTHER METAL/steel

NARRATIVE DESCRIPTION (see continuation sheets 7-5 through 7-27).

United States Department of the Interior
National Park Service

National Register of Historic Places Continuation Sheet

Section 7 Page 5

Washington Avenue Bridge
Waco, McLennan County, Texas

The Washington Avenue Bridge (1902), a pin-connected, steel Pennsylvania through-truss, spans the Brazos River north of downtown Waco, Texas. The bridge is located 200 yards west of the Waco Suspension Bridge (1870; NR 1970). Built for two-way access, both traffic lanes on the bridge now run in one direction (southwesterly), carrying vehicular traffic from Elm Avenue to Washington Avenue. Pedestrian traffic continues in both directions. The length of the main span is 450 feet. Two approach spans measure 67 feet on the east side and 40 feet on the west, resulting in a total length of 557 feet. The total width, including roadway and sidewalks, is 41½ feet. At its highest point, the truss is 60 feet above the road surface. In excellent condition, the Washington Avenue Bridge maintains a high degree of historic integrity.

The area surrounding the Washington Avenue Bridge is predominately flat, with a sharp drop at the riverbank. The bridge is level with the elevation of the surrounding roads. The river, on average, is approximately 380 feet wide and 20 feet deep. Both banks are sandy at the surface, covering a thick layer of shale containing interbeds of soft chalk. The riverbanks in the vicinity of the bridge are public park areas.

The bridge's substructure consists of four piers, 96 inches in diameter, one under each inclined end post (Figure 3). The piers are poured-in-place concrete, with the top 20 feet clad in $\frac{3}{8}$ -inch rolled steel plate. Each pair of piers is braced and clad with $\frac{3}{8}$ -inch steel plates and angles, riveted diagonally between the them. The bracing is placed only at the top 18 feet of each pier (Figure 4). The inclined end posts are attached to the piers with a 6-inch diameter steel pin. On the west side the connection assembly is bolted to the top of the pier (Figure 5). To accommodate expansion and contraction the pinned connection assembly on the east side is allowed to slide on rails that are anchored to the top of the piers (Figure 6).

The loads imposed on the deck of the bridge are supported by two top chords, braced with perpendicular and diagonal struts, constructed of angle and lattice bracing, (Figure 7). The top chord is made up of 16 individual girders, all pin-connected (Figure 8). The girders are composed of 13 individual steel members (Figure 9). The overall dimensions of the top chord are $32\frac{3}{4}$ " x 26".

United States Department of the Interior
National Park Service

National Register of Historic Places Continuation Sheet

Section 7 Page 6

Washington Avenue Bridge
Waco, McLennan County, Texas

Two types of vertical members transfer the loads from the decking to the top chord. The primary vertical members define the individual truss panels, and terminate at the point where girders in the top chord meet (at each bend in the top chord). The secondary verticals are at the center of each truss panel. The primary verticals are made of two channels (C-12 x 25), which are braced with lattice cross-bracing (Figure 10). The secondary verticals are made of two parts. The first spans from the floor beam to the pin connection at the mid-point of the truss panel. This section is constructed the same way as the primary verticals. The rest of the vertical member is made from four angles (5" x 3" x $\frac{3}{8}$ ") which are braced in the center (Figure 11).

The diagonal members are designed to act in tension only. They are constructed with $1\frac{1}{8}$ " x $6\frac{3}{16}$ " eye bar in the two center panels, and $1\frac{3}{8}$ " x 7" eye bar in the remaining panels. These eye bars are pinned: at the intersection of the first primary vertical member and the top chord; at the center of the truss panel with the secondary vertical member; and at the intersection of the lower chord, and the second primary vertical. Pins of $4\frac{1}{2}$ -inch diameter are used throughout this assembly, except at the lower chord, where 5" pins are installed (Figure 12).

The structural members that make up the supports for the decking consist of: floor beams, fabricated from steel plate and angles measuring 48" high; stringers; lower chord, made up of six eye bars ($1\frac{1}{16}$ " x 6"); and bottom lateral bracing, (5" x 3" x $\frac{3}{8}$ "). The floor beams are riveted to the vertical members, while the lower chords are connected to the verticals with 5" diameter pins (Figure 13).

The pedestrian railing is original but has been modified (Figure 14). A postcard postmarked April 27, 1911, shows a railing with round ornament at each post just below the handrail (Figure 15). The railings currently measure $40\frac{1}{2}$ inches high, but a 1901 article in the *Waco Weekly Tribune*, noted that the railings were four feet high.¹ A pipe railing (also visible in Figure 15) was also removed at an undetermined time.

Braces between the vertical members and the struts feature modest ornamentation. At each end of the bridge, a five-point star is cut out of each metal portal brace. The interior braces feature trefoil and tear drop patterns cut out of the center (Figures 16 and 17).

United States Department of the Interior
National Park Service

National Register of Historic Places Continuation Sheet

Section 7 Page 7

Washington Avenue Bridge
Waco, McLennan County, Texas

The original roadway width of 24 feet was reduced to 21¹/₂ feet after the installation of 32¹/₂"-inch high guardrails, installed to protect truss members from vehicular impact damage. The guardrails are mounted with four bolts into the concrete decking, and on the main span they are also bolted to the main vertical members of the truss (Figure 18). Illinois Steel USA manufactured the steel guardrail sections, but the installation date and contractor are unknown.

The Washington Avenue Bridge was last inspected by the Bridge Inventory, Inspection and Appraisal (BRINSAP) office on September 11, 1996. BRINSAP inspects, evaluates, and rates bridges. The information is stored in a computer data base, and a complete inventory of historic bridges is maintained. The records are updated every two years, and the results are submitted to the counties (Table 1). The current condition of the bridge is rated as "Fair condition - minor deterioration of structural elements (extensive)."² The weakest element of the bridge is the superstructure, which is also rated as being in fair condition. The main problems with the superstructure are corrosion of structural elements and cracking of certain pin nuts at the pin connections. In the final recommendations, the Washington Avenue Bridge was approved for continued use with a gross loading limitation of 32,000 lbs., and a maximum axle or tandem load of 21,000 lbs. The recommendations also call for an annual structural inspection.

All of the structural components of the Washington Avenue Bridge are original. Therefore, the annual inspections will help properly maintain the bridge by identifying any problems. The maintenance program has kept a coat of paint on the steel, and the decking in top condition. The foundations have withstood bombardment from debris floating down the flooding Brazos, and to this day show no signs of failure. The truss members are all original, with little indication of structural fatigue. The concrete decking has been replaced at least once, although the date and contractor's name have not been recorded. The only other alterations were made to the pedestrian railings and the installation of guardrails along the roadway.

¹ *Waco Weekly Tribune* (June 29, 1901), p. 2

² Robert E. Ferrell, P. Eng., Bridgfarmer & Associates, Inc. Consulting Engineers, *Bridge Inspection Record*, p. 1.

United States Department of the Interior
National Park Service

National Register of Historic Places

Continuation Sheet

Section 7 Page 8

Washington Avenue Bridge
Waco, McLennan County, Texas

At the time of its construction, the Washington Avenue Bridge was the longest single-span truss bridge in the southwest. Today, the Washington Avenue Bridge is the longest and oldest single-span vehicular truss bridge still in use in the United States. The bridge is an excellent example of a truss system popular at the turn of the century, but now rapidly disappearing from American roads. The bridge contains a high percentage of original material and is still used for its intended purpose. The Washington Avenue Bridge maintains its integrity of location, setting, workmanship, materials, design, feeling, and association, and remains worthy of preservation.

United States Department of the Interior
National Park Service

National Register of Historic Places Continuation Sheet

Section 7 Page 9

Washington Avenue Bridge
Waco, McLennan County, Texas

FIGURE 1
Northeast bank of Brazos River, Waco Suspension Bridge on right

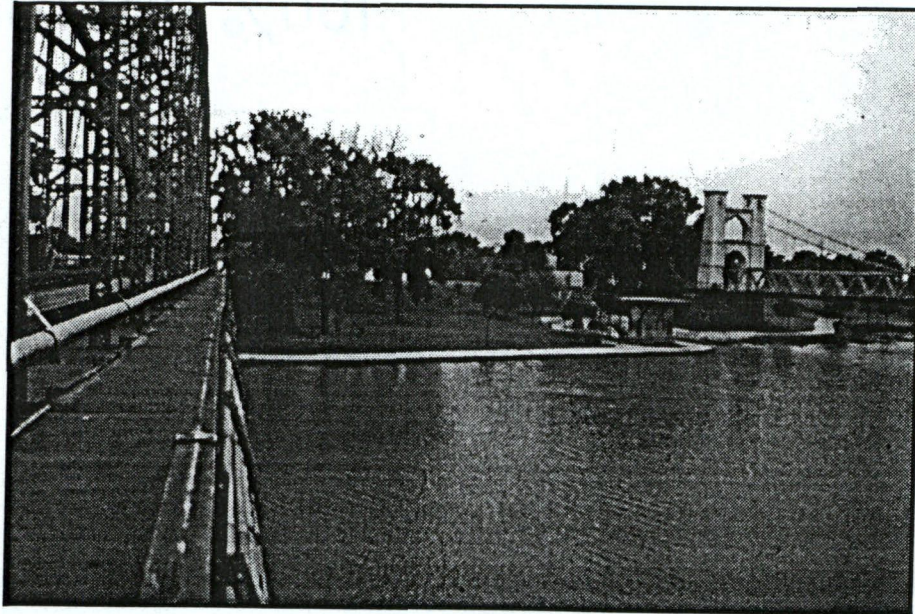

United States Department of the Interior
National Park Service

National Register of Historic Places Continuation Sheet

Section 7 Page 10

Washington Avenue Bridge
Waco, McLennan County, Texas

FIGURE 2

Postcard, circa 1910

Source: Baylor University, Waco, Texas. The Texas Collection. Events - Waco Floods file

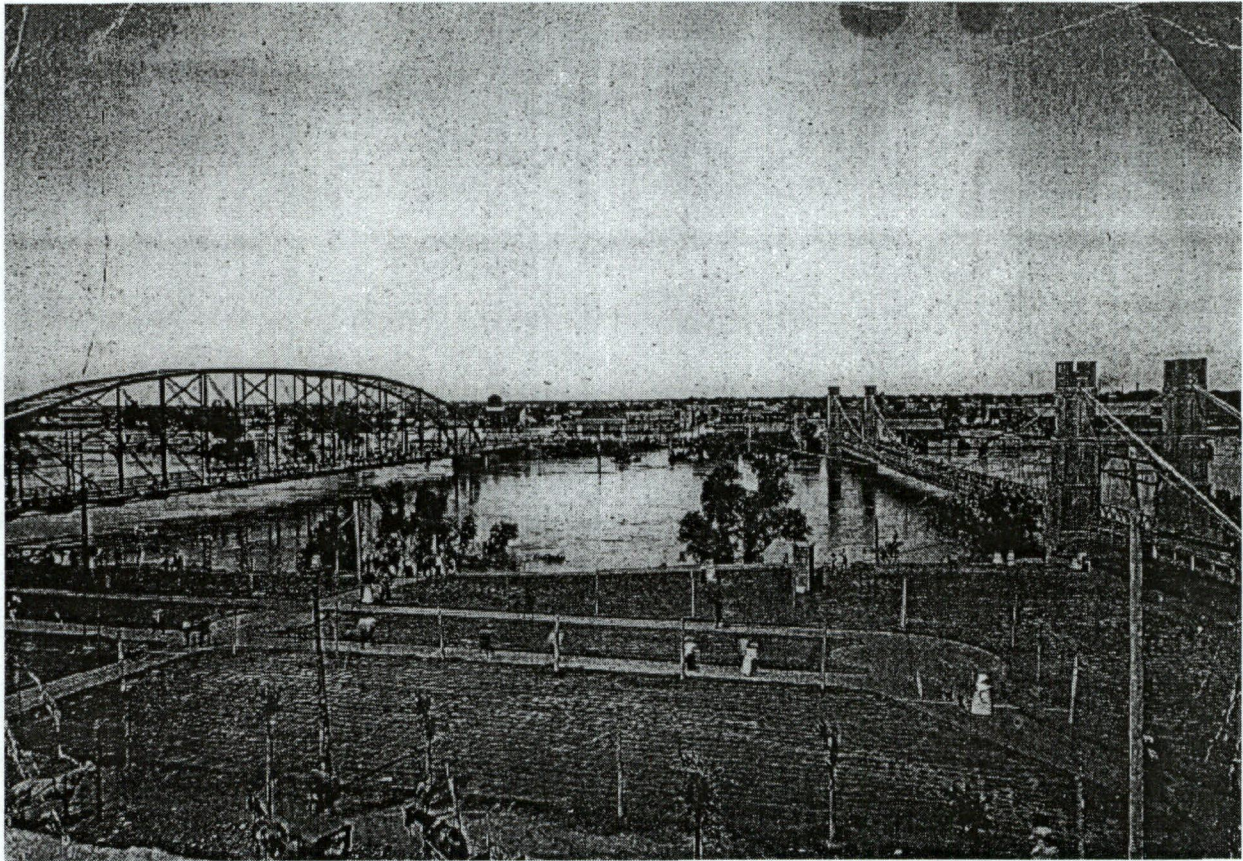

United States Department of the Interior
National Park Service

National Register of Historic Places Continuation Sheet

Section 7 Page 11

Washington Avenue Bridge
Waco, McLennan County, Texas

FIGURE 3
Bridge substructure
Source: Author



United States Department of the Interior
National Park Service

National Register of Historic Places Continuation Sheet

Section 7 Page 12

Washington Avenue Bridge
Waco, McLennan County, Texas

FIGURE 4
Bridge substructure
Source: Author

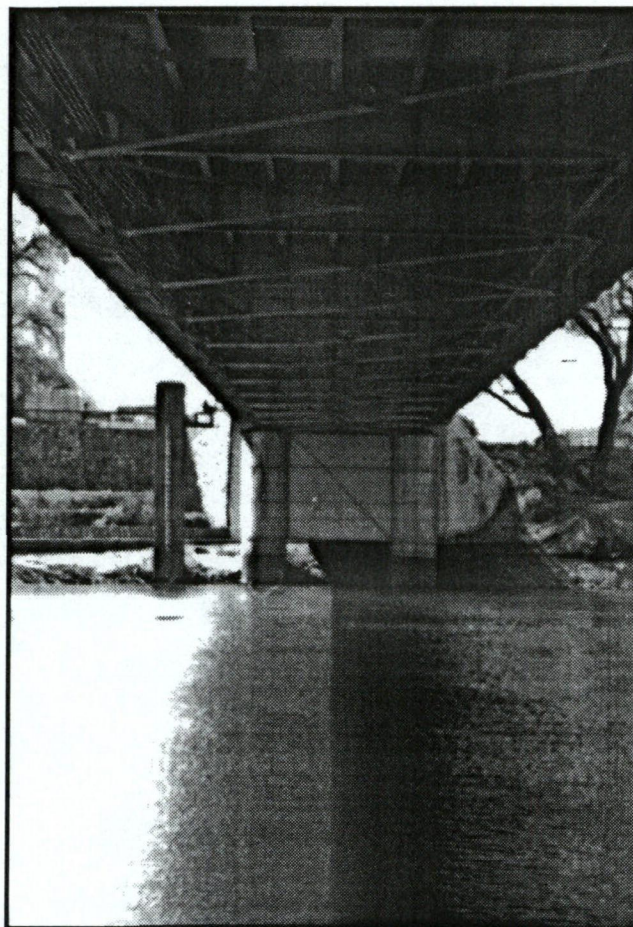

United States Department of the Interior
National Park Service

National Register of Historic Places Continuation Sheet

Section 7 Page 13

Washington Avenue Bridge
Waco, McLennan County, Texas

FIGURE 5
Southwest pier
Source: Author

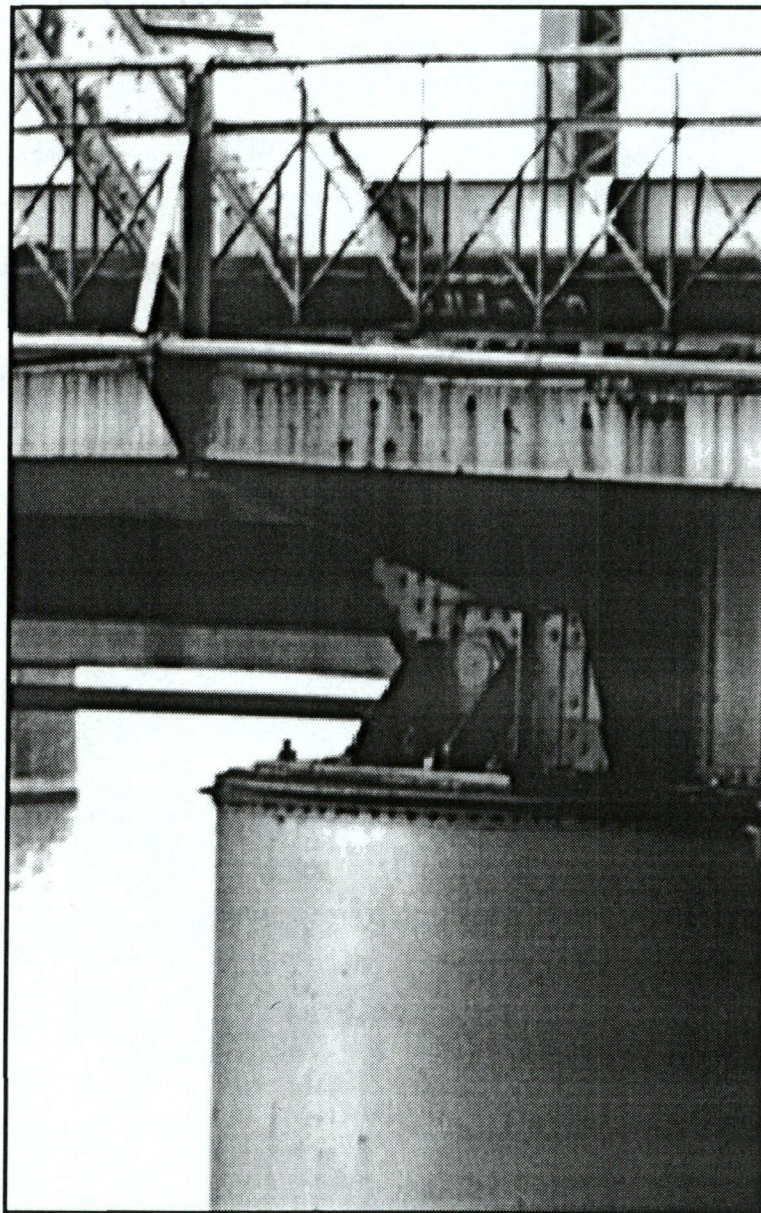

United States Department of the Interior
National Park Service

National Register of Historic Places Continuation Sheet

Section 7 Page 14

Washington Avenue Bridge
Waco, McLennan County, Texas

FIGURE 6
Southeast pier
Source: Author

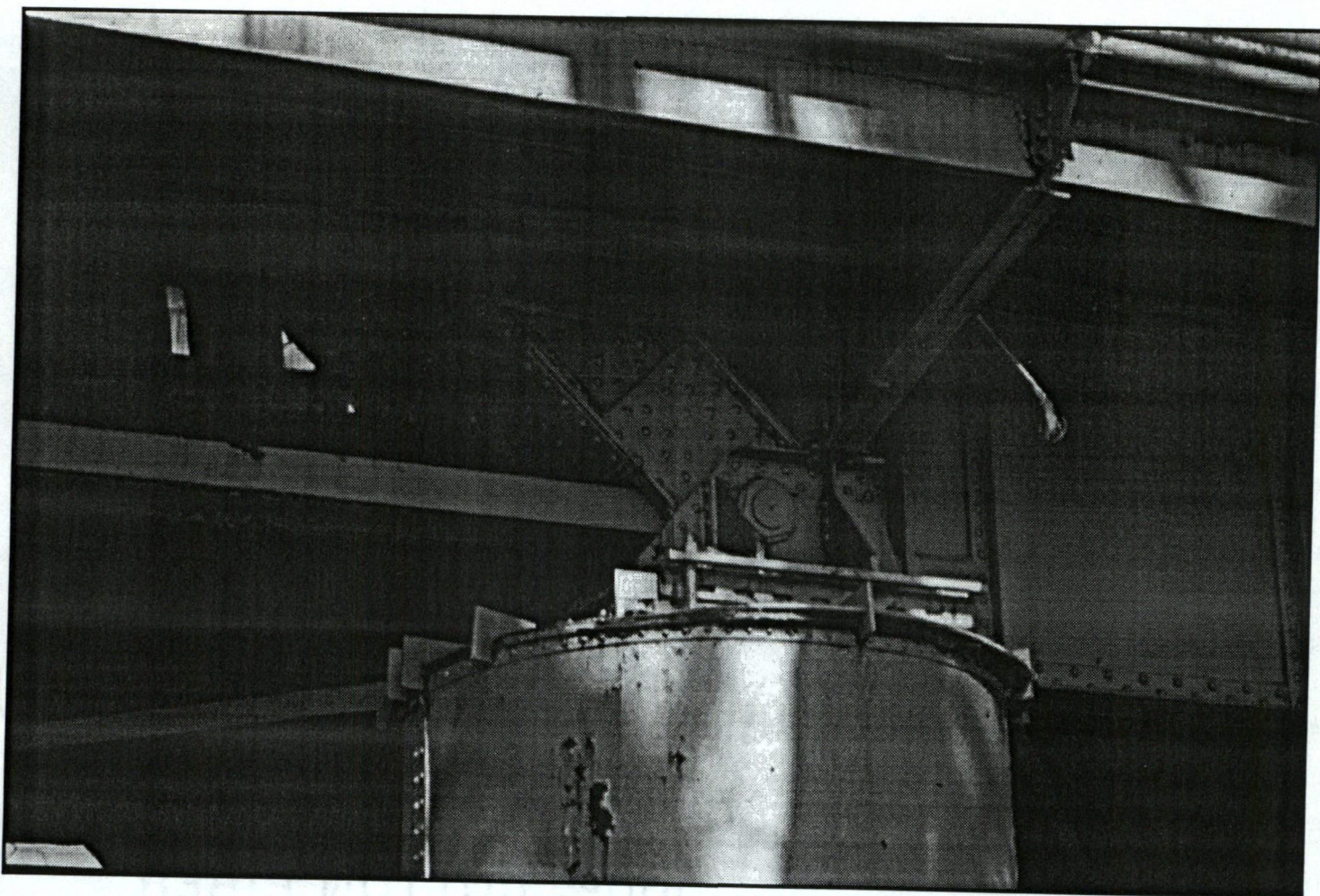

United States Department of the Interior
National Park Service

National Register of Historic Places Continuation Sheet

Section 7 Page 15

Washington Avenue Bridge
Waco, McLennan County, Texas

FIGURE 7
Top chord detail
Source: Author



United States Department of the Interior
National Park Service

National Register of Historic Places Continuation Sheet

Section 7 Page 16

Washington Avenue Bridge
Waco, McLennan County, Texas

FIGURE 8

Drawing by: A. J. Tullock Prop'r MO Valley Bridge & Iron Works
Source: City of Waco Engineering Office

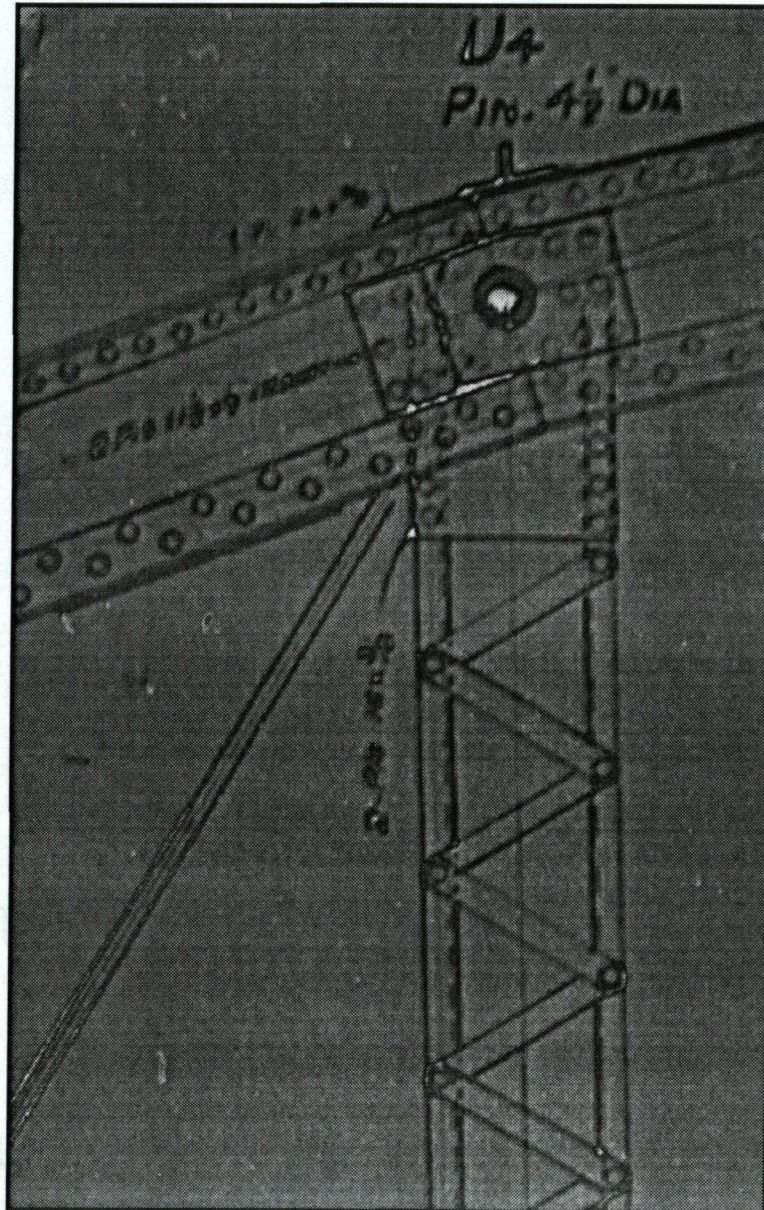

United States Department of the Interior
National Park Service

National Register of Historic Places Continuation Sheet

Section 7 Page 17

Washington Avenue Bridge
Waco, McLennan County, Texas

FIGURE 9
Girder cross-section
Source: Author

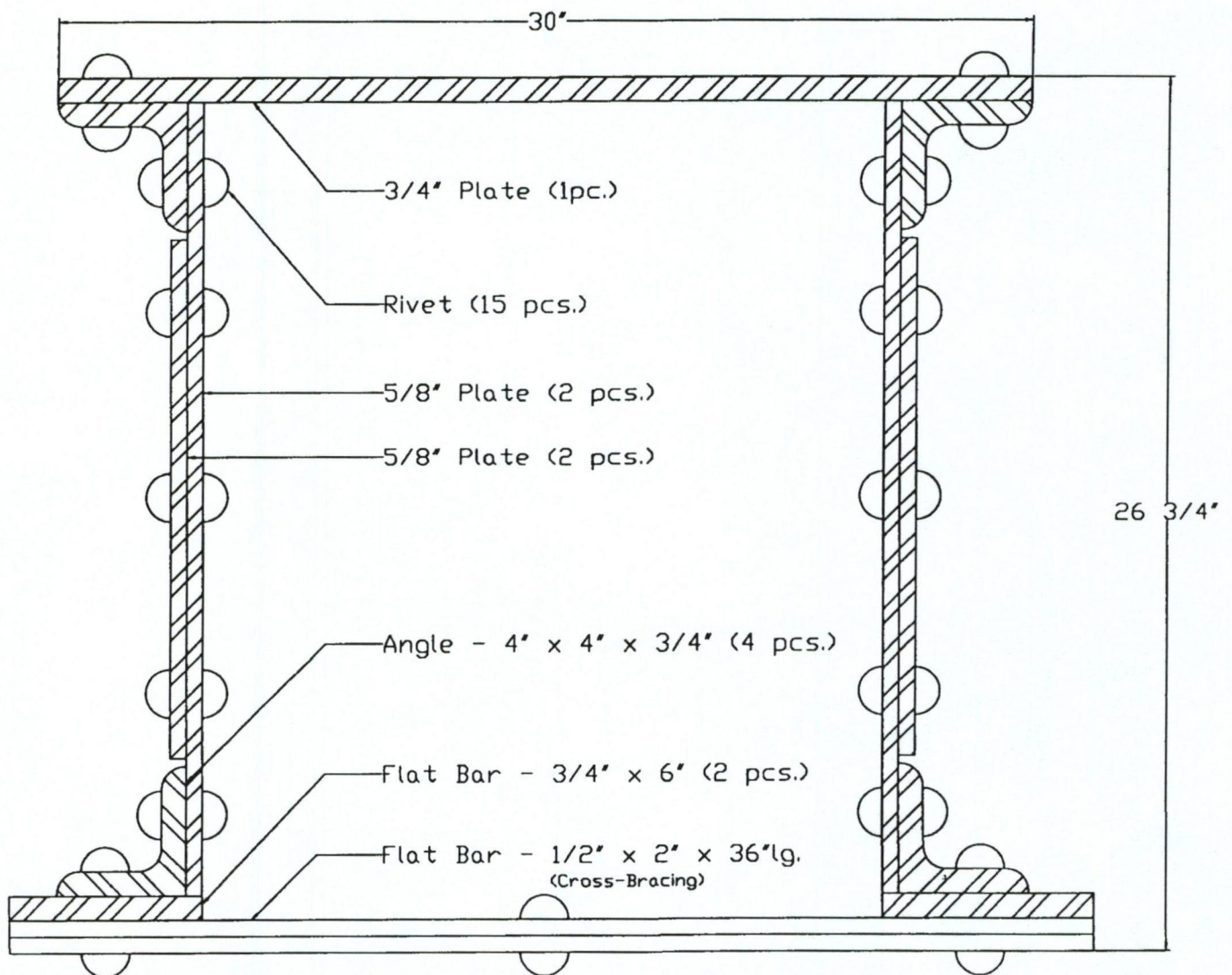

United States Department of the Interior
National Park Service

National Register of Historic Places Continuation Sheet

Section 7 Page 18

Washington Avenue Bridge
Waco, McLennan County, Texas

FIGURE 10
Primary verticals cross-section
Source: Author

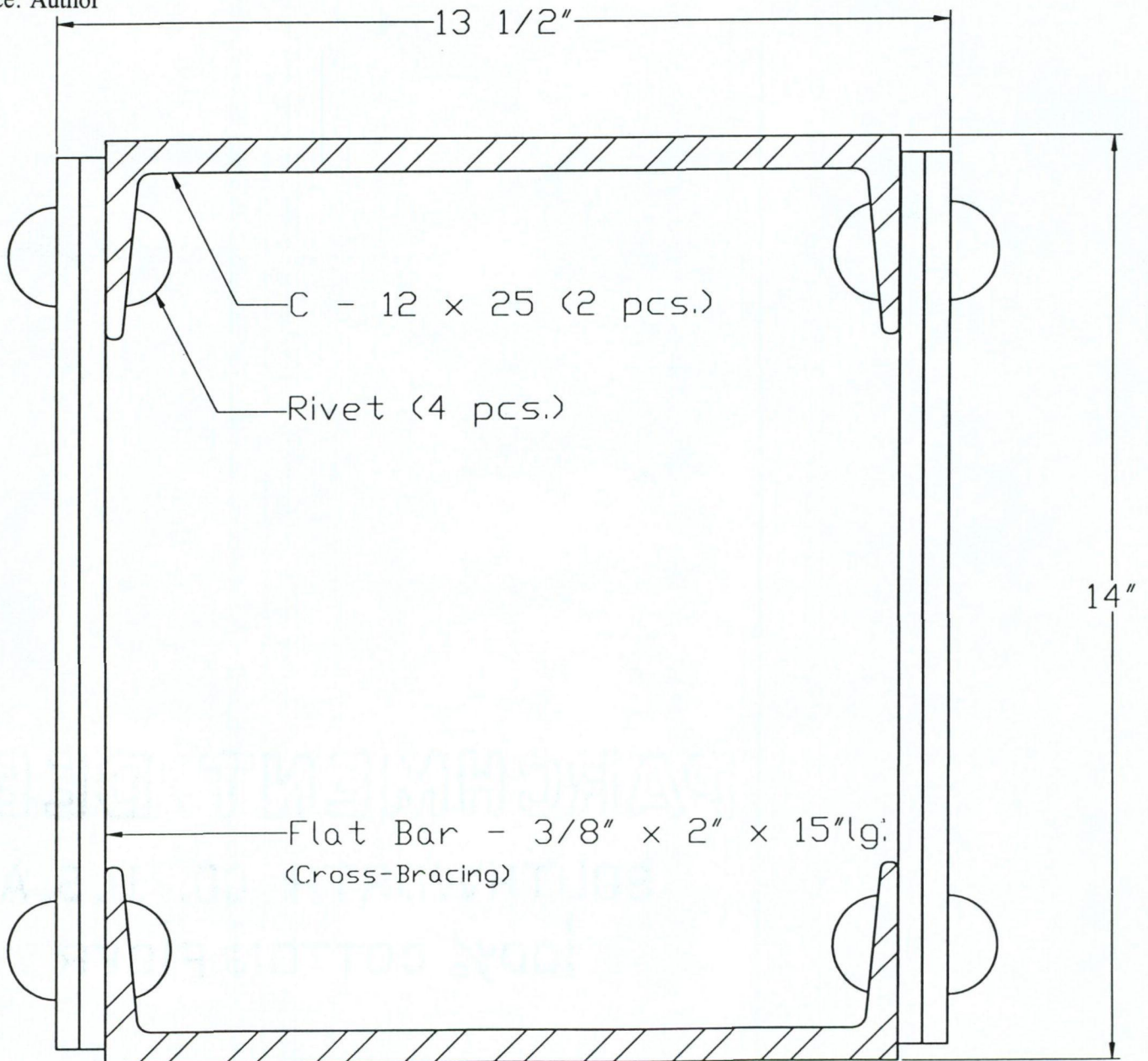

United States Department of the Interior
National Park Service

National Register of Historic Places Continuation Sheet

Section 7 Page 19

Washington Avenue Bridge
Waco, McLennan County, Texas

FIGURE 11
Vertical member cross-angle
Source: Author

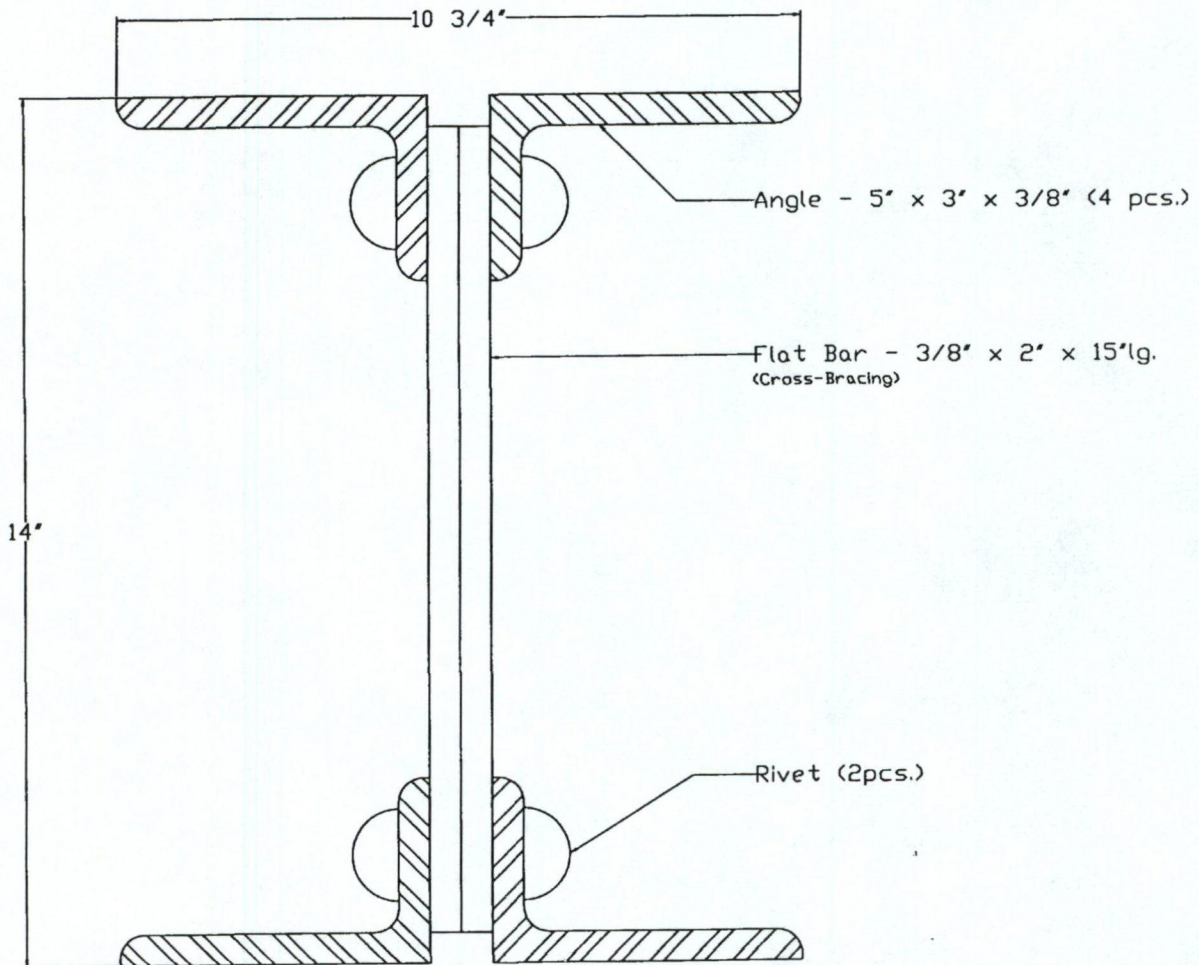

United States Department of the Interior
National Park Service

National Register of Historic Places Continuation Sheet

Section 7 Page 20

Washington Avenue Bridge
Waco, McLennan County, Texas

FIGURE 12

Drawing by: A. J. Tullock Prop'r MO Valley Bridge & Iron Works
Source: City of Waco Engineering Office.

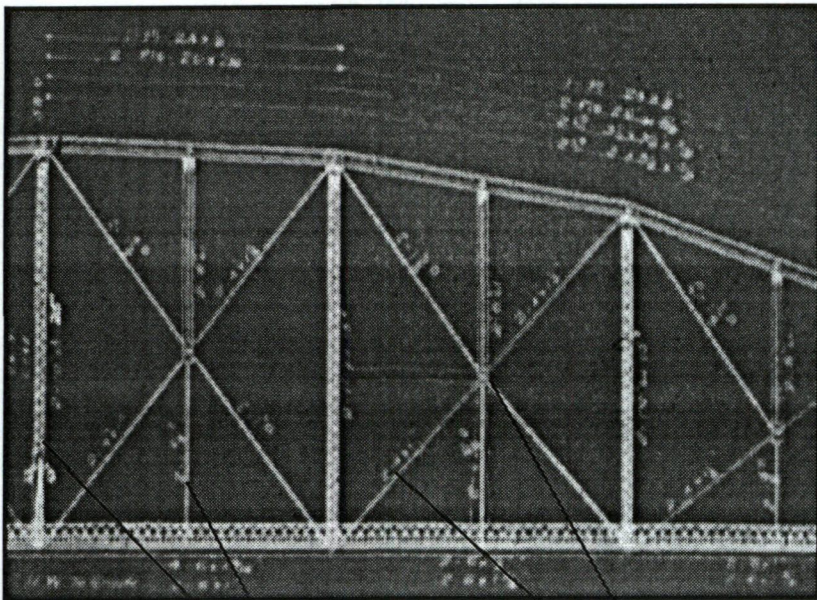

primary vertical —

diagonal bracing —

secondary vertical —

pin connection —

United States Department of the Interior
National Park Service

National Register of Historic Places Continuation Sheet

Section 7 Page 21

Washington Avenue Bridge
Waco, McLennan County, Texas

FIGURE 13
Decking supports
Source: Author



United States Department of the Interior
National Park Service

National Register of Historic Places Continuation Sheet

Section 7 Page 22

Washington Avenue Bridge
Waco, McLennan County, Texas

FIGURE 14
Railing ornamentation
Source: Author

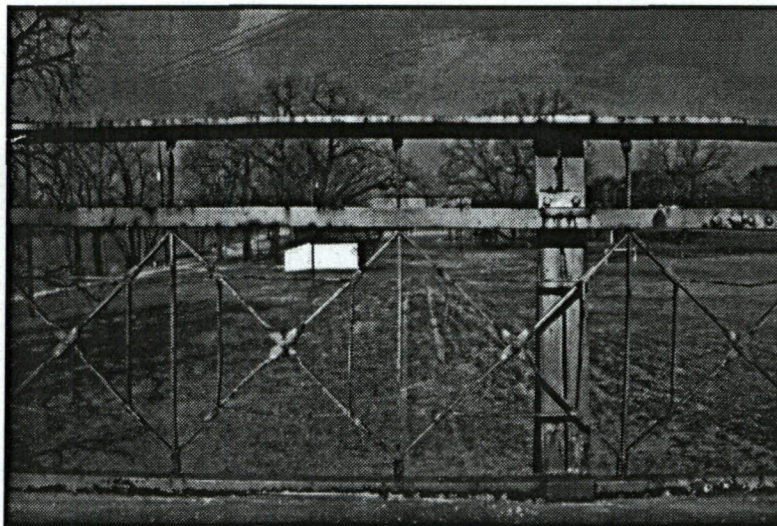

United States Department of the Interior
National Park Service

National Register of Historic Places Continuation Sheet

Section 7 Page 23

Washington Avenue Bridge
Waco, McLennan County, Texas

FIGURE 15

Postcard, postmarked April 27, 1911

Source: Baylor University, Waco, Texas (The Texas Collection., Washington Avenue Bridge post card file).

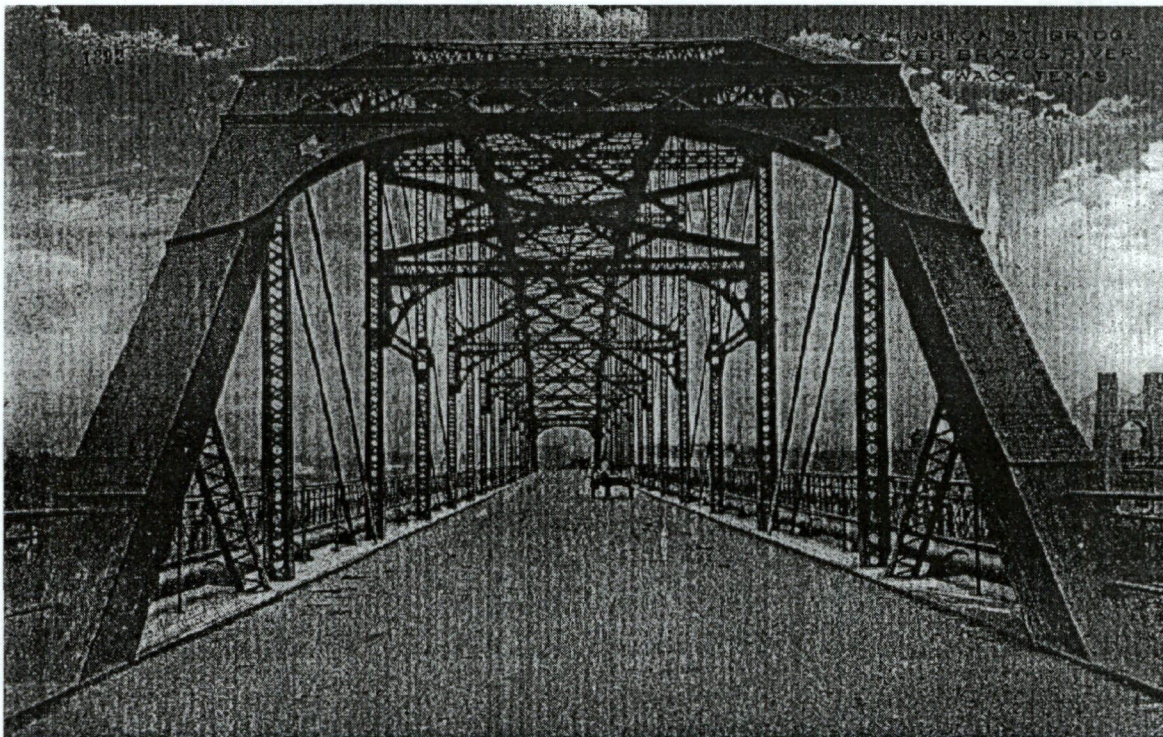

United States Department of the Interior
National Park Service

National Register of Historic Places Continuation Sheet

Section 7 Page 24

Washington Avenue Bridge
Waco, McLennan County, Texas

FIGURE 16
Interior brace with star motif
Source: Author



United States Department of the Interior
National Park Service

National Register of Historic Places Continuation Sheet

Section 7 Page 25

Washington Avenue Bridge
Waco, McLennan County, Texas

FIGURE 17
Interior brace with trefoil motif
Source: Author



United States Department of the Interior
National Park Service

National Register of Historic Places Continuation Sheet

Section 7 Page 26

Washington Avenue Bridge
Waco, McLennan County, Texas

FIGURE 18
Guardrail and gas pipeline
Source: Author



United States Department of the Interior
National Park Service

National Register of Historic Places Continuation Sheet

Section 7 Page 27

Washington Avenue Bridge
Waco, McLennan County, Texas

TABLE 1

BRINSAP Summary of Findings.

Source: Texas Department of Transportation. BRINSAP Record. Inspection report by Bridgefarmer & Associates, Inc. Inspection report, 1996.

Component	Rating	Description
Deck (concrete)	6	deck has minor cracking, joint seals have failed
Superstructure (steel truss)	5	minor rust on truss members and pins
Substructure (concrete and steel)	7	abutments have minor cracks, rust at bent caps
Approaches	6	minor cracks in relief joints and decking
Channel (banks, bed, toe walls)	8	
Overall bridge rating	5	operating rate 32,000 lbs. gross 21,000 lb. tandem axle

Legend:

- N - Not Applicable
- 9 - Excellent Condition
- 8 - Very good Condition
- 7 - Good Condition - minor problems
- 6 - Satisfactory Condition - minor deterioration of structural elements (limited)
- 5 - Fair Condition - minor deterioration of structural elements (extensive)
- 4 - Poor Condition - deterioration significantly affects structural capacity
- 3 - Serious Condition - deterioration seriously affects structural capacity
- 2 - Critical Condition - bridge should be closed until repair
- 1 - Failing Condition - bridge closed but repairable
- 0 - Failed Condition - bridge is closed and not repairable

8. STATEMENT OF SIGNIFICANCE

APPLICABLE NATIONAL REGISTER CRITERIA

- A** PROPERTY IS ASSOCIATED WITH EVENTS THAT HAVE MADE A SIGNIFICANT CONTRIBUTION TO THE BROAD PATTERNS OF OUR HISTORY.
- B** PROPERTY IS ASSOCIATED WITH THE LIVES OF PERSONS SIGNIFICANT IN OUR PAST.
- C** PROPERTY EMBODIES THE DISTINCTIVE CHARACTERISTICS OF A TYPE, PERIOD, OR METHOD OF CONSTRUCTION OR REPRESENTS THE WORK OF A MASTER, OR POSSESSES HIGH ARTISTIC VALUE, OR REPRESENTS A SIGNIFICANT AND DISTINGUISHABLE ENTITY WHOSE COMPONENTS LACK INDIVIDUAL DISTINCTION.
- D** PROPERTY HAS YIELDED, OR IS LIKELY TO YIELD, INFORMATION IMPORTANT IN PREHISTORY OR HISTORY.

CRITERIA CONSIDERATIONS: N/A

AREAS OF SIGNIFICANCE: Engineering

PERIOD OF SIGNIFICANCE: 1902

SIGNIFICANT DATES: 1902

SIGNIFICANT PERSON: N/A

CULTURAL AFFILIATION: N/A

ARCHITECT/BUILDER: Engineer unknown/J. H. Sparks

NARRATIVE STATEMENT OF SIGNIFICANCE (see continuation sheets 8-28 through 8-35).

9. MAJOR BIBLIOGRAPHIC REFERENCES

BIBLIOGRAPHY (see continuation sheet 9-36 through 9-37).

PREVIOUS DOCUMENTATION ON FILE (NPS): N/A

- preliminary determination of individual listing (36 CFR 67) has been requested.
- previously listed in the National Register
- previously determined eligible by the National Register
- designated a National Historic Landmark
- recorded by Historic American Buildings Survey #
- recorded by Historic American Engineering Record #

PRIMARY LOCATION OF ADDITIONAL DATA:

- State historic preservation office (*Texas Historical Commission*)
- Other state agency (*Texas Department of Transportation*)
- Federal agency
- Local government
- University (*Baylor University, Texas Collection*)
- Other -- Specify Repository:

United States Department of the Interior
National Park Service

National Register of Historic Places
Continuation Sheet

Section 8 Page 28

Washington Avenue Bridge
Waco, McLennan County, Texas

The Washington Avenue Bridge (1902) was the second permanent vehicular structure built across the Brazos River in Waco, Texas. The Waco Suspension Bridge (NR 1970) provided the first permanent crossing one block down river (east) in 1870. The 1902 bridge was, at the time of construction, the longest single-span vehicular truss bridge in Texas. Due to the 450-foot span, a truss system with a bowed top chord had to be used, and the Pennsylvania truss - useful in spanning great distances - was chosen. The Washington Avenue Bridge opened to traffic on June 30, 1902, forming a vital link between two main thoroughfares, Washington Avenue on the west bank and Elm Avenue on the east.³ The contract was awarded to J. H. Sparks of St. Joseph, Missouri, at a cost of \$93,300.⁴ The railings and approach spans were constructed by Mess Hill Bros. at a cost of \$1,850.⁵ John Wharton Maxey of Houston served as supervising engineer. McLennan County and the City of Waco each contributed \$50,000 to meet the expenses, resulting in joint ownership of the bridge.

The Washington Avenue Bridge contributed to the rapid economic and demographic growth of Waco in the early part of the 20th century. The bridge is eligible under criterion C, in the area of Engineering, at the local level of significance, as the longest single span truss bridge in the southwest.

At the time of its construction, the Washington Avenue Bridge was a vital, reliable link across the often flooding Brazos River. It relieved the load from the Suspension Bridge, and allowed safe and fast passage for the residents of Waco, as well as visiting investors. By the turn of the century, Waco was growing rapidly, and traffic across the Brazos River had to flow as freely as its water. Today, six vehicular bridges, two railway bridges, and one pedestrian bridge cross the Brazos River along a 3 mile section of downtown Waco. At the turn of the century, however, only the Washington Avenue Bridge, the Waco Suspension Bridge, and two railway bridges (the Missouri-Kansas-Texas Railroad and St. Louis-Southwestern Railroad), provided passage over the Brazos.

The banks of the Brazos River, at what is today Waco, were first mapped and documented by Spanish explorer Luis De Moscoso de Alvarado in 1542. At that time a small Huaco Indian village named 'Guasco' occupied the west

³ *Waco Tribune-Herald*, June 16, 1967.

⁴ "The New Bridge", *Waco Weekly Tribune*, June 29, 1901, pp. 1-2.

⁵ *McLennan County Commissioner's Court Minutes, 1899-1902*, May 20, 1902, p. 578.

United States Department of the Interior
National Park Service

National Register of Historic Places Continuation Sheet

Section 8 Page 29

Washington Avenue Bridge
Waco, McLennan County, Texas

bank. The Indians settled there because of the spring which flows to this day just downstream of the Suspension Bridge. It wasn't until 1845 that a Scottish frontiersman named Neill McLennan established the first non-Indian settlement on the west bank of the Brazos River. In 1848, George B. Erath, a surveyor, settled on the west side and in 1849 laid out streets and lots for the town of Waco. Shortly thereafter, Captain Shapley P. Ross purchased land on the banks of the Brazos River, and opened a ferry service to carry passengers and cargo across the river. The town of Waco was officially incorporated in 1857. After the Civil War, Waco was severely drained of financial resources; but the city recovered quickly due to its location along the Chisholm Cattle Trail. Large numbers of people and cattle passed through Waco and the need for a permanent structure across the Brazos River grew. With increased traffic Captain Ross' Ferry service was far from reliable since the river flooded often, sometimes making crossing impossible for several days. In 1866, the Waco Bridge Company was contracted to build a toll-financed suspension bridge.

The suspension bridge was completed in January 1870, and was opened as a privately operated toll bridge. The county contract awarded to the Waco Bridge Company contained a clause that forbade construction of any other bridge or ferry across the Brazos River within five miles of the suspension bridge. As a result, people were forced either to cross at the bridge and pay the toll, or try fording in low water. In order to prevent fording, the Waco Bridge Company purchased the land in the vicinity of the bridge and constructed barriers. It did not take long for the public to become frustrated with the monopoly held by the bridge company, and demand that the county either buy the bridge or build a new one. In 1886, a county election authorized the county to provide a free crossing. For the next year, McLennan County failed to reach an agreement with the owners of the bridge. The county then accepted offers to construct a wrought iron bridge one block farther upstream (at the present location of the Washington Avenue Bridge). In 1888, a federal judge in Dallas ruled that the contract signed by the Waco Bridge Company was legal and binding; as a result, plans for the new bridge had to be halted. Finally, in July 1889, McLennan County officials agreed to pay the bridge company's asking price of \$75,000, and on September 1, 1889, the suspension bridge became public property.

The opening of free access across the Brazos was a great relief to the rapidly growing Waco population. From 1879 to 1889, the population of Waco increased by almost 8,000 residents, spurred by the introduction of three

United States Department of the Interior
National Park Service

National Register of Historic Places Continuation Sheet

Section 8 Page 30

Washington Avenue Bridge
Waco, McLennan County, Texas

railroads to the area.⁶ The Southern Pacific Railroad acquired the Waco Tap Railroad, construction of which was started in 1870, but never completed. The company was renamed Waco and Northwestern Railroad, and provided a link from Waco to Bremond to Houston. This connection became a vital commercial link for Waco, as Houston – already a large city at that time – supplied Waco with goods, business contacts and new residents. In 1881, a second railroad, St. Louis-Southwestern Railway of Texas, opened a track and constructed a bridge across the Brazos approximately 400 yards downstream from the suspension bridge. This company went into receivership twice before being bought out by the Southern Pacific Railway Company in 1930. The third major railroad, the Missouri-Kansas-Texas Railroad (Katy), opened on January 23, 1882. Katy constructed a bridge across the Brazos approximately 300 yards downstream from the suspension bridge, and provided Waco with connections to Dallas, Fort Worth, and Austin. Similar to the Southern Pacific Railroad, Katy was responsible for the movement of a great deal of goods and commerce between Waco and other major urban centers.

The population of Waco grew from 15,005 in 1890 to 24,304 in 1900.⁷ With a increasing number of residents and visitors crossing the Brazos River, a second bridge had to be added to accommodate all the wagon and pedestrian traffic. The placement of the new bridge provided an important link between the residential east bank to the industrial/commercial west side. Until the completion of the Waco Drive Bridge along U.S. Route 84 (circa 1930), the two vehicular bridges provided the only connection between the two halves of the city.⁸ Today eight vehicular bridges, and one pedestrian bridge cross the Brazos River in Waco. In 1996, the population of Waco City Proper was 104,500.⁹ In 1930, the two bridges each had to accommodate 26,424 residents; but in 1996 each of the eight bridges serves only 13,063 residents.

The Washington Avenue Bridge is an 18-panel, pin-connected Pennsylvania truss. The Pennsylvania truss evolved from the Parker truss, developed by C. H. Parker in the late 1800s. The Parker truss, in turn, was influenced by the Pratt through-truss, developed by Thomas and Caleb Pratt in 1844 (Figure 18). The Pennsylvania truss was popular between 1885 and 1910, with span lengths ranging from approximately 200 feet to 670 feet. The longest

⁶ Morrison & Fourmy Directory Co., *Directory of the City of Waco 1913*, p. 4.

⁷ *Ibid.*

⁸ Dayton Kelley, *The Handbook of Waco and McLennan County, Texas*, p. 53.

United States Department of the Interior
National Park Service

National Register of Historic Places Continuation Sheet

Section 8 Page 31

Washington Avenue Bridge
Waco, McLennan County, Texas

recorded Pennsylvania truss vehicular bridge, constructed in 1912 in St. Louis, Missouri, across the Mississippi River, had a span of 668 feet. At the time of its construction, the Washington Avenue Bridge was the 16th longest single-span truss bridge in North America, the tenth longest *vehicular* single-span truss bridge, and the longest span in the southwest (Figure 19).¹⁰ Many Waco residents claimed that the Washington Avenue Bridge was the longest single span in the country, evidenced by a postcard printed around the turn of the century, which depicts the Washington Avenue Bridge beneath the caption "New Bridge, longest single Span in the U. S., Waco, Texas" (Figure 20).

Even though its maximum length status turned out to be a false assumption, the Washington Avenue Bridge is an important landmark, significant under Criterion C. This bridge played a vital role in the development of the Waco community during a time of intense growth. Local traffic depended on this reliable river crossing year round and especially during flooding seasons. Moreover, the bridge has maintained its integrity and original use, and remains the longest surviving single-span vehicular truss bridge built before 1903 in the United States.

The Washington Avenue Bridge has a high degree of integrity of location, setting, workmanship, materials, design, feeling, and association. The location of the bridge has remained the same since its construction. Due to this bridge's placement next to the famed Waco Suspension Bridge, the area between the two bridges was allocated, from the beginning, as a public park, and Waco residents and tourists still enjoy the picturesque view of the two bridges. All the structural members are original, including the concrete foundations and the approach spans. The Washington Avenue Bridge was a tremendous undertaking for a Texas city, and the fact that the bridge has remained in service is a testament to suburb workmanship.

⁹ R. L. Polk & Co. *Folk City Directory 1996, Waco, Texas*, pp. 8.

¹⁰ Thadeus Merrima and Thos. H. Wiggin. *American Civil Engineers' Handbook*, Fifth Edition (1942), p 1222.

United States Department of the Interior
National Park Service

National Register of Historic Places Continuation Sheet

Section 8 Page 32

Washington Avenue Bridge
Waco, McLennan County, Texas

FIGURE 19
Typical truss bridge types
Source: Historic American Engineering Record

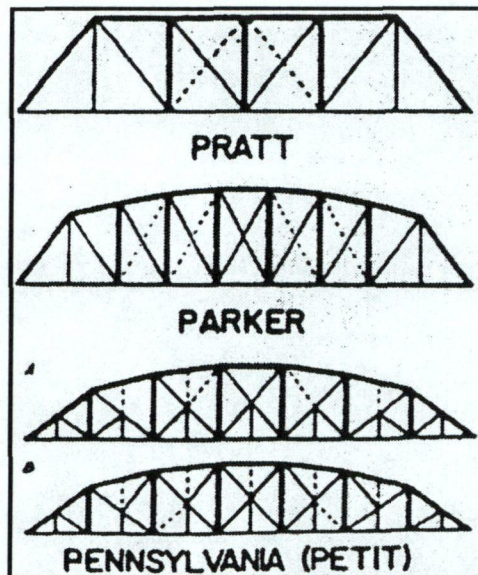

United States Department of the Interior
National Park Service

National Register of Historic Places
Continuation Sheet

Section 8 Page 33

Washington Avenue Bridge
Waco, McLennan County, Texas

FIGURE 20

Source: Merriman, Thaddeus; Wiggin, Thos, H. American Civil Engineers' Handbook. 5th ed. New York: John Wiley & Sons, Inc., 1942. pp. 1222.

Simple Truss Bridges
Long Span American Simple Bridges

Span center to center of end pins	Kind of truss	Over what river	Location	Railroad tracks		Date of com- ple- tion
				Single	Double	
720 0	Pennsylvania	Ohio	Metropolis, Ill.	*		1917
668 0	"	Mississippi	St. Louis (Municipal)	*		†1912
643 10-1/2	"	Ohio	Louisville, Ky.	*		1918
640 0	" K " truss	St. Lawrence	Quebec	*		1917
598 6	Pennsylvania	Hudson	Castleton, N. Y.	*		1924
586 0	"	Great Miami	Elizabethtown, Ohio	*		†1906
552 0	"	Ohio	Metropolis, Ill.	*		1917
546 6	"	Ohio	Louisville and Jeffer- ville	*		1894
542 6	"	Ohio	Cincinnati and Cov- ington	*		†1889
533 0	"	Delaware	Philadelphia	*		1896
531 0	"	Allegheny	Pittsburgh	*		†1914
523 0	"	Ohio	Pittsburgh (Brunot's I.)	*		1915
522 0	"	Ohio	Wheeling	*		1883
521 11-3/4	Warren	Ohio	Henderson, Ky.	*		
519 2-1/2	Pennsylvania	Ohio	Wheeling	*		†1892
518 1-3/4	Whipple	Ohio	Cairo	*		1889
518 0	Pennsylvania	Ohio	Kenova, W. Va.	*		1913
518 0	"	Susquehanna	Havre de Grace, Md.	*		1909
517 8-1/2	"	Monongahela	Glenwood, Pa.	*		†1895
517 6	"	Mississippi	St. Louis (Merchant's)	*		1890
517 6	"	Mississippi	St. Louis (McKinley)	*		†1910
515 0	"	Monongahela	West Braddock, Pa.	*		†1897
515 0	"	Monongahela	Webster to Donora, Pa.	*		†1909
506 8	"	Ohio	Newport and Cincin- nati	*		†1896
504 0	"	Susitria	Alaska	*		1921
500 0	"	Missouri	Sioux City	*		†1895
498 0	"	Monongahela	Clairton, Pa.	*		1903
495 8-1/8	"	Monongahela	Rankin, Pa.	*		1900
489 3	"	Monongahela	West Braddock, Pa.	*		†1897
484 6	"	Ohio	Cincinnati and Cov- ington	*		†1889
465 0-1/4	Parker	Miami	New Baltimore, Ohio	*		†1901
453 10	Pennsylvania	Monongahela	Pittsburgh (So. 10th St.)	*		†1904
450 0	"	Brazos	Waco, Tex.	*		†1902
447 0	"	Allegheny	Mossgrove, Pa.	*		1899
440 0	Baltimore	Missouri	Bellefontaine, Mo.	*		1893
439 3	Pennsylvania	Ohio	Pittsburgh (Neville's Island)	*		†1927
435 10	Baltimore	Miami	Hamilton, Ohio	*		†1895
434 0	Warren	Allegheny	B. & O. R. R., Pitts- burgh	*		1920
433 2-3/8	Pennsylvania	Carquinez Straits	San Francisco, Calif.	*		†1927
430 0	"	Mississippi	Red Wing, Minn.	*		†1896

† Highway traffic

United States Department of the Interior
National Park Service

National Register of Historic Places Continuation Sheet

Section 8 Page 34

Washington Avenue Bridge
Waco, McLennan County, Texas

FIGURE 21

Postcard, circa 1905

Source: Baylor University, Waco, Texas. The Texas Collection. Washington Avenue Bridge post card file.

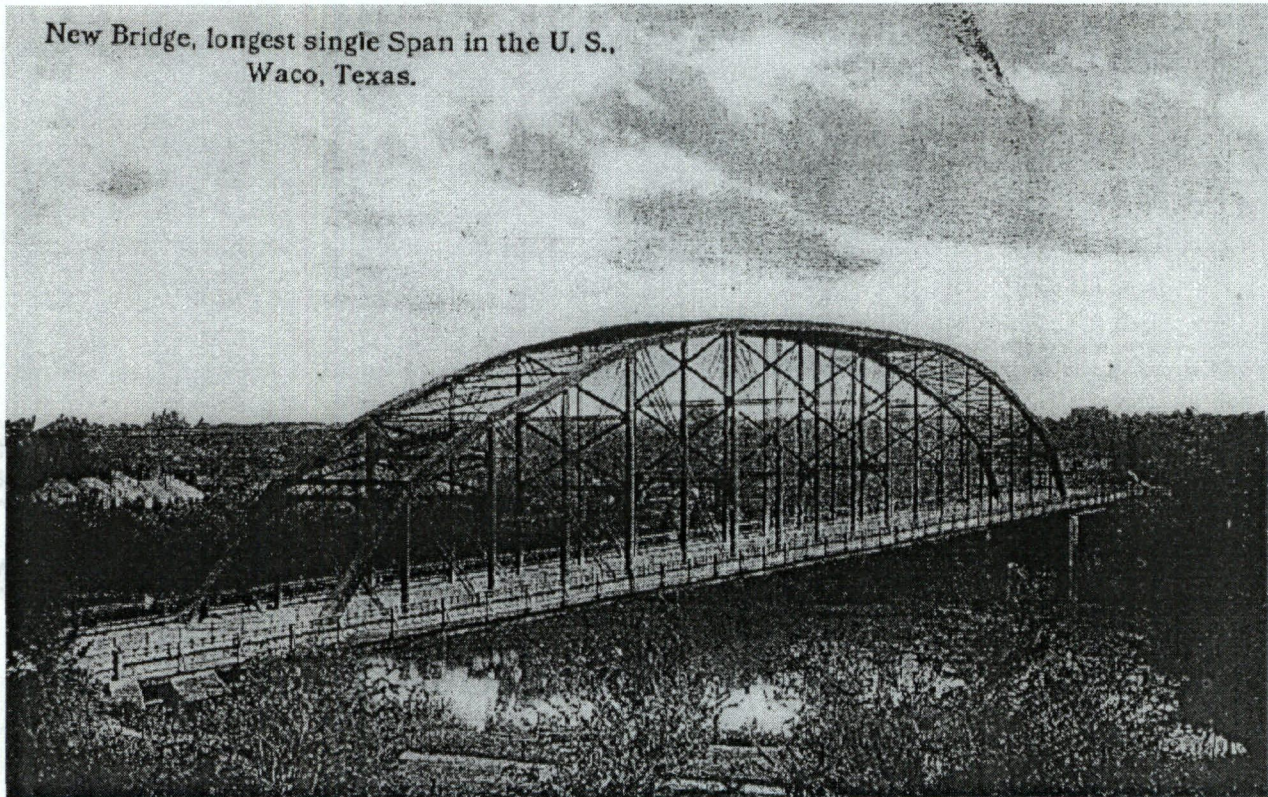

United States Department of the Interior
National Park Service

National Register of Historic Places Continuation Sheet

Section 8 Page 35

Washington Avenue Bridge
Waco, McLennan County, Texas

FIGURE 22

Washington Avenue Bridge, taken from the Waco Suspension Bridge, April 19, 1908.

Source: Card Catalogue # 156, "Waco Bridges, Washington Avenue Bridge", Texas Collection, Baylor University, Waco, Texas.



United States Department of the Interior
National Park Service

National Register of Historic Places Continuation Sheet

Section 9 Page 36

Washington Avenue Bridge
Waco, McLennan County, Texas

BIBLIOGRAPHY

- "A New Bridge of 400 ft. Span." Engineering News and American Railway Journal (August 2, 1900):69.
- Brenda, Eldon, Stephen. The Handbook of Texas, Supplement. Austin: The Texas State Historical Association, 1976.
- Conger, Roger, Norman. Highlights of Waco History. Waco: Hill Printing & Stationery Co., 1945.
- Coons, C., Wilbur. "Waco: A Typical Texas City." The Texas Magazine (April 1910):6668.
- Kelley, Dayton. The Handbook of Waco and McLennan County, Texas. Waco: Texian Press, 1972.
- Merriman, Thaddeus; Wiggin, Thos, H. American Civil Engineers' Handbook.5th ed. New York: John Wiley & Sons, Inc., 1942.
- Morrison & Fourmy Directory Co. Directory of the City of Waco 1913.Houston:Morrison & Fourmy Directory Co., 1913.
- "New Brazos Bridge." Waco Weekly Tribune (July 5, 1902):8.
- Prescott, Walter. The Handbook of Texas, vol. 1 and 2.Austin:The Texas State Historical Association,1952.
- R. L. Polk & Co. Polk City Directory 1996, Waco, Texas. Detroit: R. L. Polk & Co., 1996.
- "The New Bridge." Waco Weekly Tribune (February 8, 1902):1.
- "The New Bridge." Waco Weekly Tribune (June 29, 1901):12.
- Victor, Sally, S.; Hodge, Larry, D. " Bridging the Brazos." Texas Highways (May 1984):1419.
- Waco Times Herald (June, 16, 1967).

United States Department of the Interior
National Park Service

National Register of Historic Places Continuation Sheet

Section 9 Page 37

Washington Avenue Bridge
Waco, McLennan County, Texas

Other Sources

Baylor University, Waco, Texas. The Texas Collection. Files: Waco Bridges, Washington Avenue Bridge; Waco Bridges, Suspension Bridge; Waco Events, Floods; Aerial Views of Waco; Washington Avenue Bridge Post Cards.

City of Waco Engineering Office. Drawing by: A. J. Tullock Prop'r MO Valley Bridge & Iron Works.

McLennan County, Commissioner's Court Minutes, 1866-1875, .Page 36.

_____, Commissioner's Court Minutes, 1884-1889, September 12, 1887, p. 381.

_____, Commissioner's Court Minutes, 1884-1889, November 16, 1887, p. 419.

_____, Commissioner's Court Minutes, 1899-1902, August 13, 1890, p. 232.

_____, Commissioner's Court Minutes, 1899-1902, April 4, 1902, p. 537.

_____, Commissioner's Court Minutes, 1899-1902, May 20, 1902, p. 578.

_____, Commissioner's Court Minutes, 1902-1907, October 24, 1902, p. 28.

Texas Department of Transportation. BRINSAP Record. Inspection report by Robert E. Ferrell, P. Eng. at Bridgefarmer & Associates, Inc. Inspection report of the Washington Avenue Bridge, 1996.

Texas Department of Transportation. County Maps. 1994.

Texas Department of Transportation. Texas Historic Bridge Inventory. Washington Avenue Bridge File, Bridge I.D. # B00331001.

10. GEOGRAPHICAL DATA

ACREAGE OF PROPERTY: less than one acre

UTM REFERENCES	Zone	Easting	Northing
1	14	677630	3493110
2	14	677750	3493240

VERBAL BOUNDARY DESCRIPTION (see continuation sheet 10-38)

BOUNDARY JUSTIFICATION (see continuation sheet 10-38)

11. FORM PREPARED BY (with assistance from Gregory Smith, Historian, Texas Historical Commission)

NAME/TITLE: Matthew Haberling

ORGANIZATION: University of Texas at Austin

DATE: April 1, 1997

STREET & NUMBER: 5109 Avenue H

TELEPHONE: (512) 452-2391

CITY OR TOWN: Austin **STATE:** Texas

ZIP CODE: 78751

ADDITIONAL DOCUMENTATION

CONTINUATION SHEETS

MAPS (see continuation sheets MAP-39 through MAP-40)

PHOTOGRAPHS (see continuation sheet PHOTO-41)

ADDITIONAL ITEMS

PROPERTY OWNER

NAME: City of Waco

STREET & NUMBER: P.O. Box 2570

TELEPHONE: (817) 750-5636

CITY OR TOWN: Waco

STATE: Texas

ZIP CODE: 76702-2570

United States Department of the Interior
National Park Service

National Register of Historic Places

Continuation Sheet

Section 10 Page 38

Washington Avenue Bridge
Waco, McLennan County, Texas

VERBAL BOUNDARY DESCRIPTION

The nomination includes the Washington Avenue Bridge across the Brazos River, from the extreme limit of the north-east concrete abutment, including pedestrian railings, to the extreme limit of the south-west concrete abutment including pedestrian railings.

BOUNDARY JUSTIFICATION

The boundary includes all the historically vital components of the structure, the Washington Avenue Bridge across the Brazos River; this includes the original pedestrian railings, superstructure, substructure, and foundations, all constructed in 1902.

United States Department of the Interior
National Park Service

National Register of Historic Places Continuation Sheet

Section MAP Page 39

Washington Avenue Bridge
Waco, McLennan County, Texas

MAP: Waco, Texas (location of bridge circled)
Source: Texas Department of Transportation

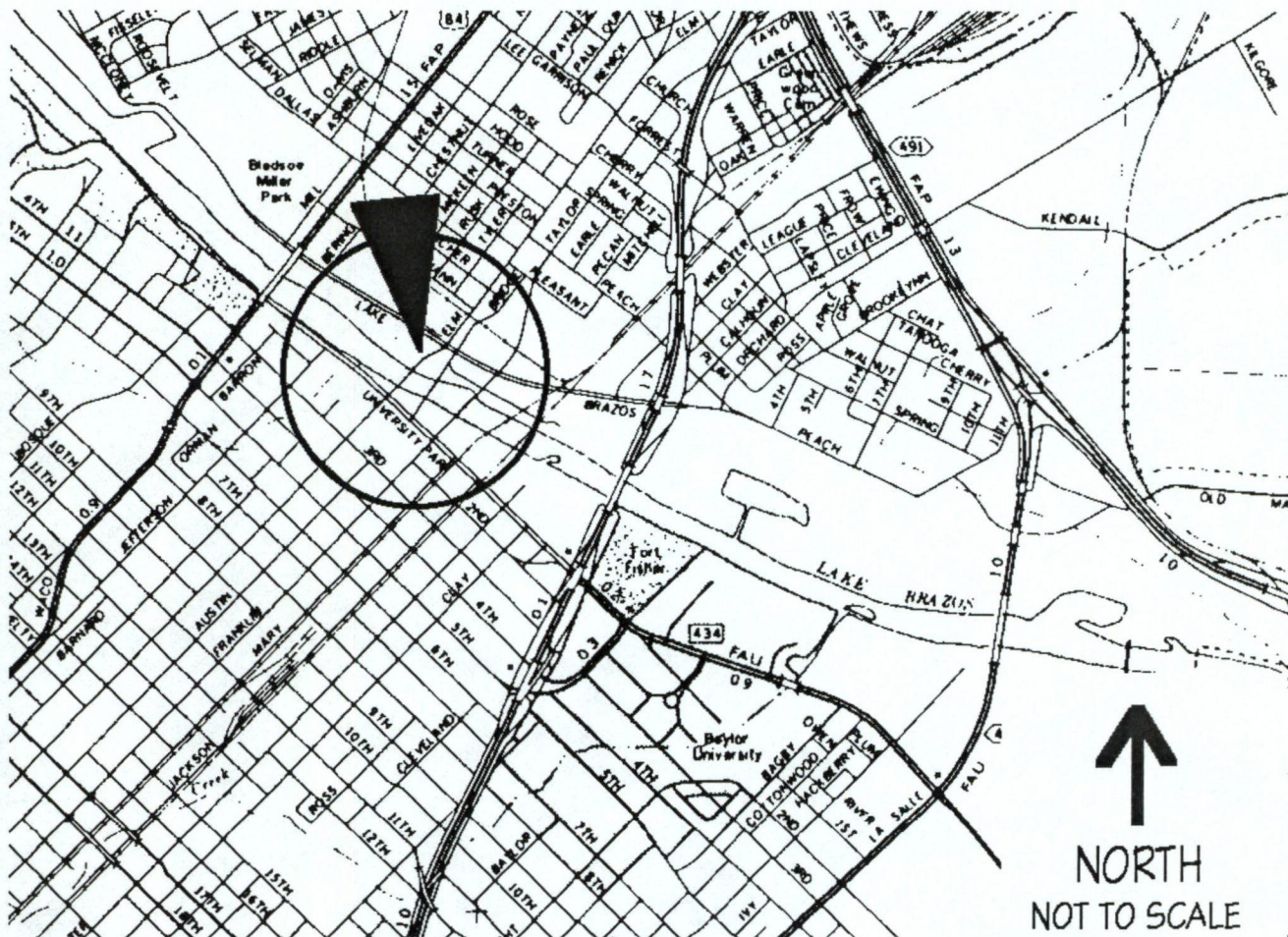

United States Department of the Interior
National Park Service

National Register of Historic Places Continuation Sheet

Section MAP Page 40

Washington Avenue Bridge
Waco, McLennan County, Texas

MAP: Site plan detail
Source: Author

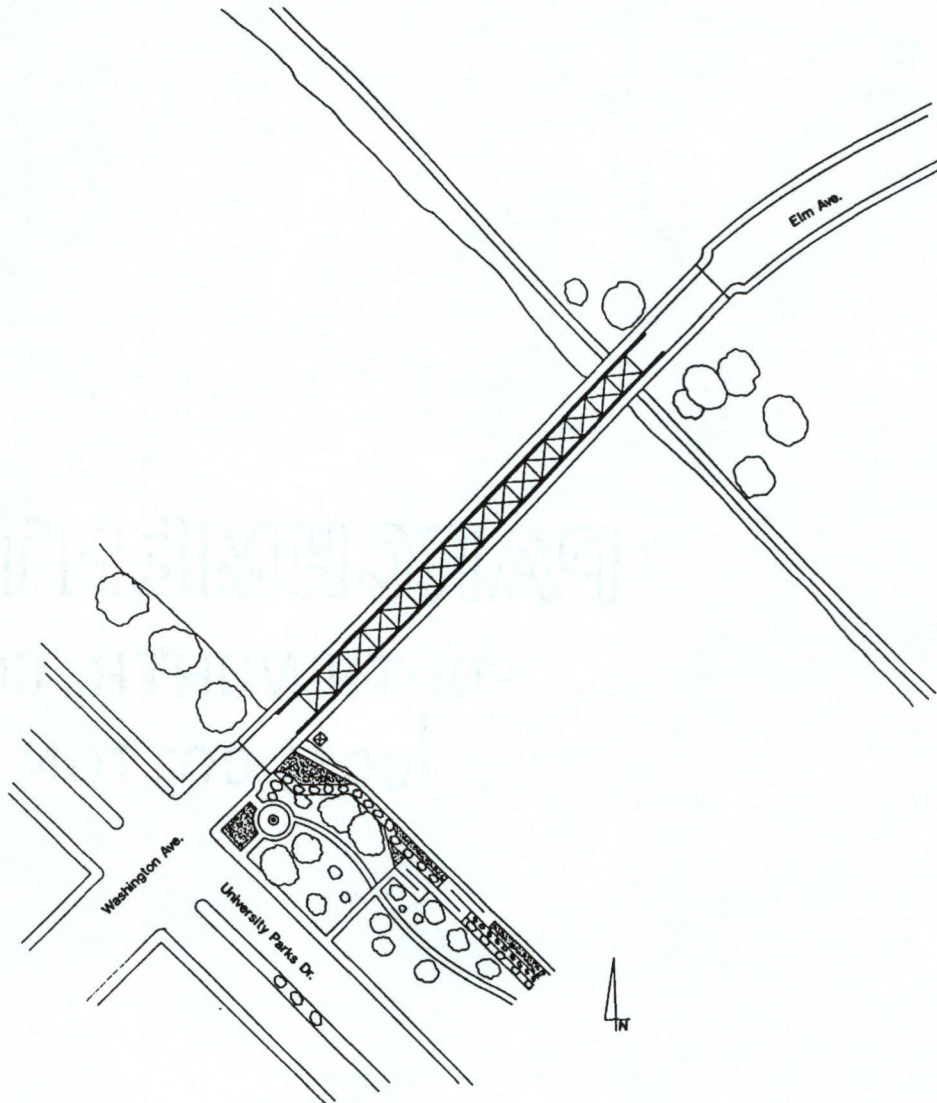

United States Department of the Interior
National Park Service

National Register of Historic Places Continuation Sheet

Section PHOTO Page 41

Washington Avenue Bridge
Waco, McLennan County, Texas

PHOTOGRAPHIC LOG

Washington Avenue Bridge at the Brazos River

Waco, McLennan County, Texas

Photograph by Matthew Haberling

March 22, 1997

Negative on file with the Texas Historical Commission, Austin, Texas.

Washington Avenue Bridge, taken from the top of the truss of the Waco Suspension Bridge, camera facing southwest.

Photograph 1 of 2.

Washington Avenue Bridge at the Brazos River

Waco, McLennan County, Texas

Photograph by Matthew Haberling

March 22, 1997

Negative on file with the Texas Historical Commission, Austin, Texas.

Washington Avenue Bridge, taken from the center of the road in front of the bridge, camera facing northeast.

Photograph 2 of 2.

UNITED STATES DEPARTMENT OF THE INTERIOR
NATIONAL PARK SERVICE

NATIONAL REGISTER OF HISTORIC PLACES
EVALUATION/RETURN SHEET

REQUESTED ACTION: NOMINATION

PROPERTY Washington Avenue Bridge
NAME:

MULTIPLE
NAME:

STATE & COUNTY: TEXAS, McLennan

DATE RECEIVED: 1/23/98 DATE OF PENDING LIST: 2/02/98
DATE OF 16TH DAY: 2/18/98 DATE OF 45TH DAY: 3/09/98
DATE OF WEEKLY LIST:

REFERENCE NUMBER: 98000143

NOMINATOR: STATE

REASONS FOR REVIEW:

APPEAL: N DATA PROBLEM: N LANDSCAPE: N LESS THAN 50 YEARS: N
OTHER: N PDIL: N PERIOD: N PROGRAM UNAPPROVED: N
REQUEST: N SAMPLE: N SLR DRAFT: N NATIONAL: N

COMMENT WAIVER: N

ACCEPT RETURN REJECT 2/20/98 DATE

ABSTRACT/SUMMARY COMMENTS:

Entered in the
National Register

RECOM./CRITERIA _____

REVIEWER _____ DISCIPLINE _____

TELEPHONE _____ DATE _____

DOCUMENTATION see attached comments Y/N see attached SLR Y/N



WASHINGTON AVENUE BRIDGE
AT BRAZOS RIVER
WACO, McLENNAN CO., TEXAS
PHOTOGRAPH 1 OF 2



WASHINGTON AVENUE BRIDGE
AT BRAZOS RIVER
WACO, McLENNAN CO., TEXAS
PHOTOGRAPH 2 OF 2

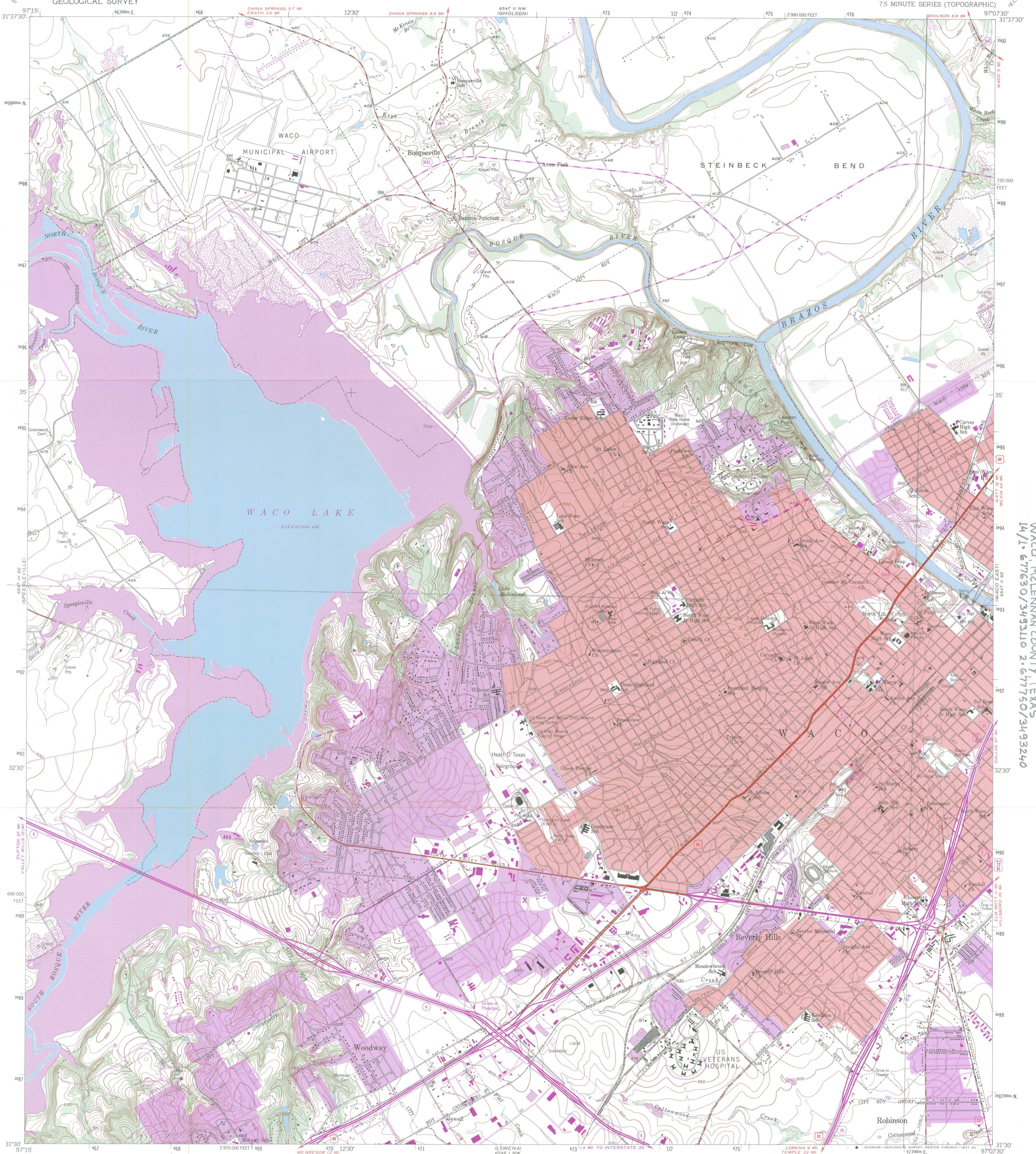

Mapped, edited, and published by the Geological Survey
Control by USGS and NOS/NOAA
Topography from 1956 planetable surveys and by ER-55 plotter
Aerial photographs taken 1955. Field check 1957
Polyconic projection. 1927 North American datum
10,000-foot grid based on Texas coordinate system,
central zone
1000-meter Universal Transverse Mercator grid ticks,
zone 14, shown in blue
Red tint indicates areas in which only
landmark buildings are shown
Revisions shown in purple compiled from aerial photographs
taken 1970 and 1975. This information not field checked
Purple tint indicates extension of urban areas

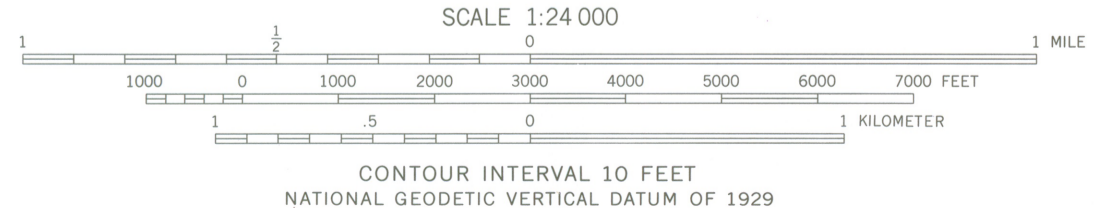
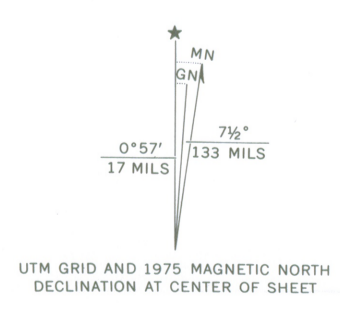

ROAD CLASSIFICATION

Primary highway, hard surface	Light-duty road, hard or improved surface
Secondary highway, hard surface	Unimproved road
Interstate Route	U. S. Route
	State Route

THIS MAP COMPLIES WITH NATIONAL MAP ACCURACY STANDARDS
FOR SALE BY U. S. GEOLOGICAL SURVEY, DENVER, COLORADO 80225, OR RESTON, VIRGINIA 22092
A FOLDER DESCRIBING TOPOGRAPHIC MAPS AND SYMBOLS IS AVAILABLE ON REQUEST

3197-412

WACO WEST, TEX.
N3130-W9707.5/7.5
1957
PHOTOREVISED 1970 AND 1975
AMS 6547 II SW - SERIES V882

WASHINGTON AVENUE BRIDGE
WASHINGTON AVENUE AT BRAZOS RIVER
WACO, MCLENNAN COUNTY, TEXAS
141.677630/3493210 2.6771750/3493240